

# 2132i and 2116i

## Temperature and Process Indicator and Alarm Units



### Installing and Operating Instructions

Thank you for choosing the 2132i or 2116i indicator and alarm unit. It will provide accurate measurement and display of temperature and other process variables with up to two alarm outputs for operator alert and process protection.

Models **2132i/AL** and **2116i/AL** are *Indicating alarm units* which come with an alarm relay output and logic I/O fitted.

Models **2132i/ND** and **2116i/ND** are *Indicator only units* which come without the alarm relay output or logic I/O fitted. Alarms can still be configured and flashed as messages in the main display but they will not be able to operate a physical output.

The indicator is supplied configured according to the ordering code given on page 5. Check the coding on the side labels to determine the configuration of your particular indicator.

### DIMENSIONS AND INSTALLATION

#### Model 2132i

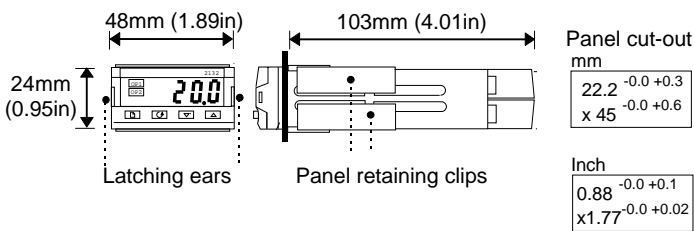

#### Model 2116i

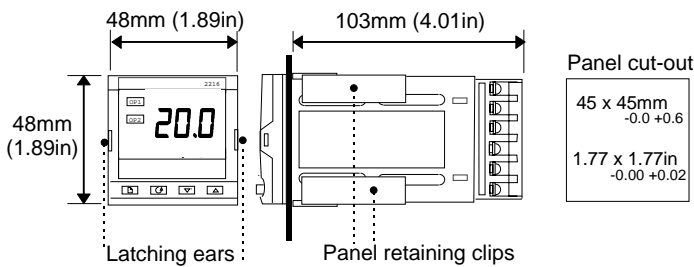

### To install the indicator

Please read the safety information on pages 5 & 6 before proceeding.

1. Prepare the panel cut-out to the size shown.
2. Insert the indicator through the cut-out.
3. Spring the panel retaining clips into place. Secure the indicator in position by holding it level and pushing both retaining clips forward.
4. Peel off the protective cover from the display

### Unplugging the indicator

The indicator can be unplugged from its sleeve by easing the latching ears outwards and pulling it forward out of the sleeve. When plugging the indicator back into its sleeve, ensure that the latching ears click into place to maintain the IP65 sealing.

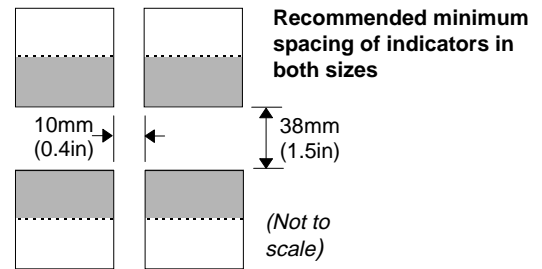

### ELECTRICAL CONNECTIONS

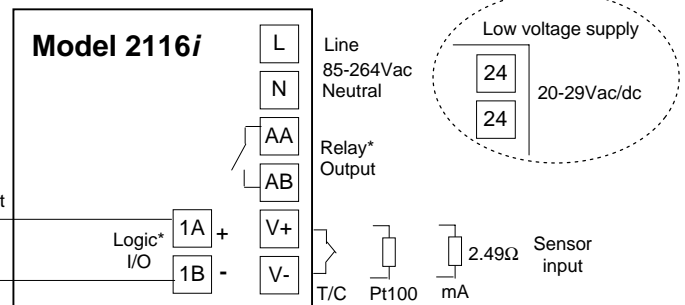
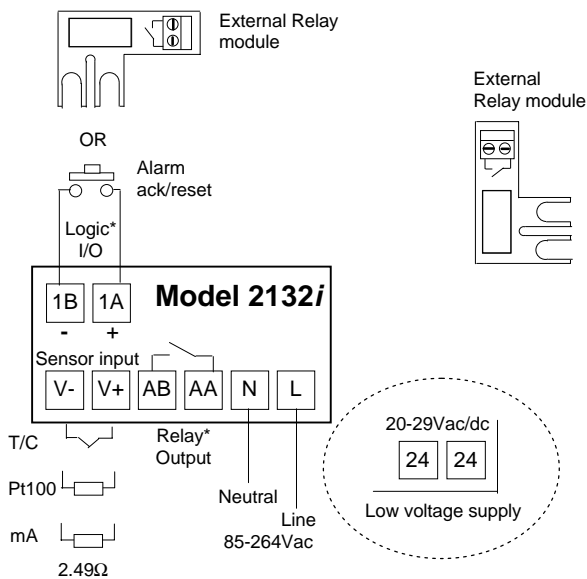

#### Output ratings

Relay: 2A, 264Vac resistive  
Logic: 9Vdc, 12mA (non-isolated from sensor input).

#### Over current protection

Use a maximum 2A fuse for the indicator supply and relay output. A suitable fuse is EN60127 (type T).

#### Wire Sizes

The screw terminals accept wire sizes from 0.5 to 1.5 mm (16 to 22 AWG). Hinged covers prevent hands or metal making accidental contact with live wires. The rear terminals screws should be tightened to 0.4Nm (3.5lb in).

Ⓢ This indicator meets the European directives on safety and EMC

\*Not fitted in indicator only units. Also terminals 1A and 1B not fitted in indicator only unit.



## OPERATION

Switch on the indicator. Following a 3 second self-test sequence, you will see the display shown below. It is called the HOME display.

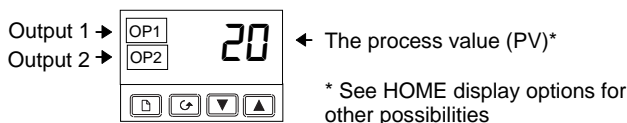

## ALARM INDICATION

The indicator has three internal 'soft' alarm setpoints which can be attached to either the logic or relay outputs.

OP1 will flash when an alarm attached to the logic output becomes true. (This is normally alarm 1). It will go steady when the alarm is acknowledged but still true.

OP2 will flash when an alarm attached to the relay output becomes true. (This is normally alarm 2 or 3). It will go steady when the alarm is acknowledged but still true.

## TO ACKNOWLEDGE A NEW ALARM

Press and together. This will also reset any latched alarms that are no longer true.

In addition to the OP beacons, alarm messages are flashed in the main display. The tables below list all of the possible messages and their meaning.

## ALARM MESSAGES

Process Alarms	
Message	Meaning
1FSL	Alarm 1 is active and it is a Low alarm.
1FSH	Alarm 1 is active and it is a High alarm.
2FSL	Alarm 2 is active and it is a Low alarm.
2FSH	Alarm 2 is active and it is a High alarm.
3FSL	Alarm 3 is active and it is a Low alarm.
5.br	Sensor Break: Input sensor is open circuit or high resistance. Check the sensor.

In addition to the above messages, the displayed process value will flash if the input signal or the displayed value is out of range.

The table above shows normal process alarms. In the event of a failure in the indicator or the sensor the following diagnostic alarm messages are provided.

Diagnostic alarms	
Message	Meaning and (Action)
EEEr	Electrically Erasable Memory Error: A parameter value has been corrupted. Contact Eurotherm Controls.
HwEr	Hardware error. (Return for repair)
LLLL	Low display range exceeded: (Check input signal)
HHHH	High display range exceeded: (Check input signal)
Err1	Error 1: ROM self-test fail. (Return for repair)
Err2	Error 2: RAM self-test fail. (Return for repair)
Err3	Error 3: Watchdog fail. (Return for repair)
Err4	Error 4: Keyboard failure. Stuck button, or a button was pressed during power up.
Err5	Error 5: Input circuit failure. (Return for repair)
Pwr.F	Power failure. The line voltage is too low.

## TO VIEW THE DISPLAY UNITS

Press and release quickly the or button. The display units will be flashed for 0.5sec

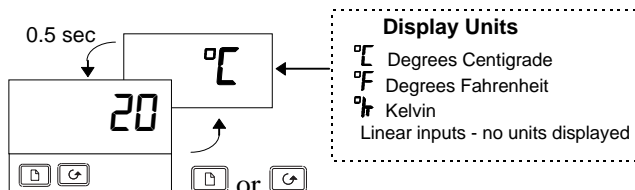

If you get lost, pressing and together will return you to the HOME display.

If, at any time, no key is pressed within 45 seconds, the display will always return to the HOME display.

## HOME DISPLAY OPTIONS

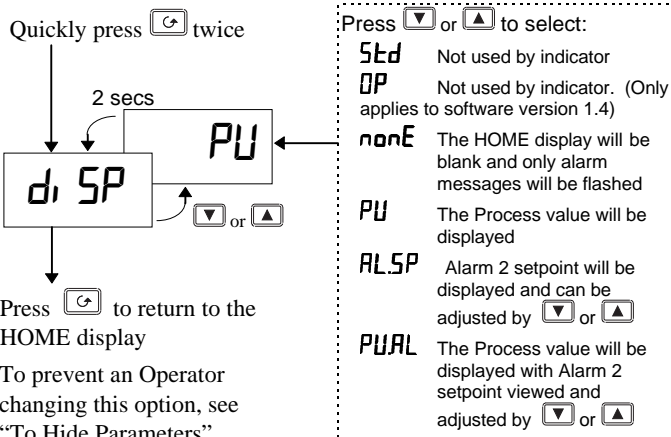

## TO CHANGE THE ALARM SETPOINTS (TRIP LEVELS)

The button steps through parameter list headings. The first list is the alarm setpoints. The other lists are shown on the next page.

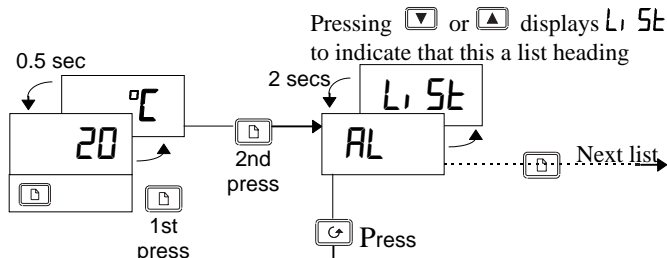

There are three alarm setpoints. The first character is the alarm setpoint number, the next three the alarm type, as follows:  
-FSL Low alarm  
-FSH High alarm

If an alarm has been disabled, it will not appear in this list.

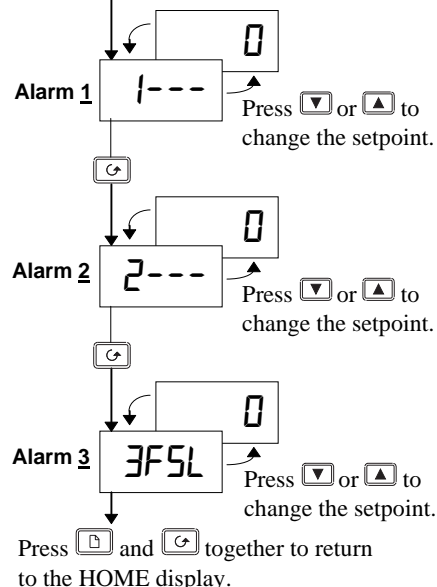

## PARAMETER LISTS

Use these lists to change: • The alarm setpoints • The alarm setpoint limits • User calibration.

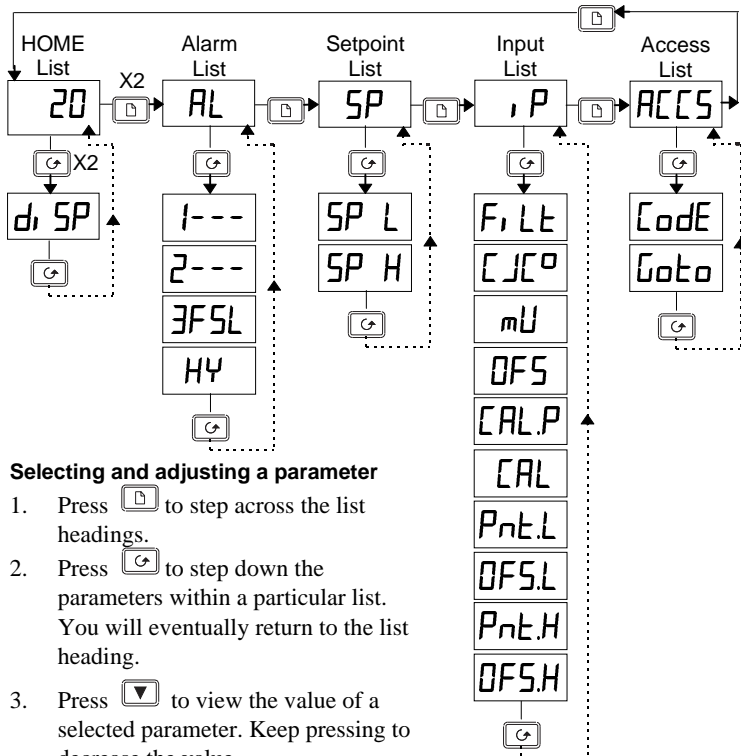

### Selecting and adjusting a parameter

1. Press **[D]** to step across the list headings.
2. Press **[G]** to step down the parameters within a particular list. You will eventually return to the list heading.
3. Press **[V]** to view the value of a selected parameter. Keep pressing to decrease the value.
4. Press **[A]** to view the value of a selected parameter. Keep pressing to increase the value.

### Parameter tables

HOME	Home List	Selectable options	Default setting
d SP	HOME display options	See HOME display options on page 2	PU

AL	Alarm setpoints	Adjustable Range	Default setting
*1---	Alarm 1 setpoint	Between low and high setpoint limits	0
*2---	Alarm 2 setpoint		0
3FSL	Alarm 3 setpoint		0
HY	Alarm Hysterisis	1-9999 PV units	1

\*In place of dashes, the last three letters indicate the alarm type:  
FSL = Low alarm. FSH = High alarm

SP	Setpoint limits	Adjustable Range	Default setting
SP L	Setpoint low limit	Between Process	As per order code
SP H	Setpoint high limit	Value min & max	code

I P	Input List	Adjustable Range	Default setting
Filt	Input filter time in secs	OFF-999.9	1.6
OFS	Process value offset	0-9999 units	0
CJC°	Cold junction temperature at the rear term'ls		Read-only
mV	mV input at the rear terminals		Read-only
CALP	Calibration password	0-9999	3
CAL	Calibration type.	FACT (Factory) USER (User)	FACT
PntL	Low calibration point	See User Calibration	0
OFSL	Low point offset		0
PntH	High calibration point		100
OFSH	High point offset		0

ACCS	Access list	Used for re-configuring the indicator.
------	-------------	--

## TO HIDE PARAMETERS OR MAKE THEM READ-ONLY

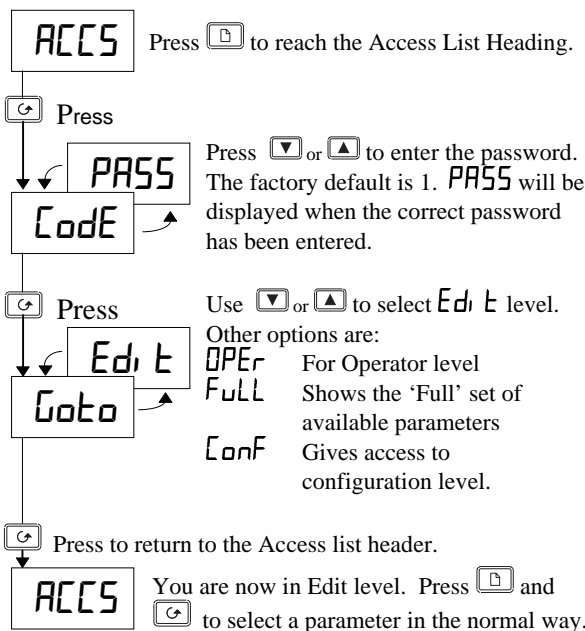

**Example:** High alarm 2 has been selected. When **[V]** or **[A]** is pressed, instead of displaying the parameter value, its availability to Operator is shown as follows:  
**ALtE** The parameter will be alterable  
**PrO** The parameter will be 'promoted' into the HOME list  
**rEAd** The parameter will be read-only  
**Hi dE** The parameter will be hidden.

Repeat for all the parameters you wish to hide or make read-only then return to operator level:

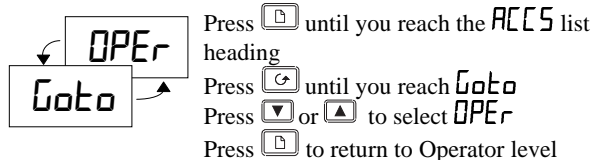

## USER CALIBRATION

Your indicator has been calibrated for life against known reference sources in the factory. User calibration allows you to apply offsets to compensate for sensor and other system errors. The parameter **OFS** in the **I P** list applies a fixed offset over the whole display range. You may also apply a 2-point calibration as follows:

- Press **[D]** until you reach the **I P** list
- Press **[G]** until you reach the **CALP** parameter
- Press **[V]** or **[A]** to enter the password. The factory default is 3. **PASS** will be displayed when correct.
- Press **[G]** to reach the **CAL** parameter
- Press **[V]** or **[A]** to select **USER** (**FACT** will restore the factory calibration)
- Apply 2-point calibration as below:

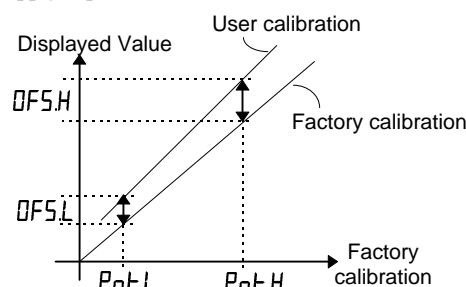

## CONFIGURING THE INDICATOR

Select configuration level to change: •The display units •The input sensor type •The scaling of linear inputs •The alarm configuration •The passwords.

### To select configuration level

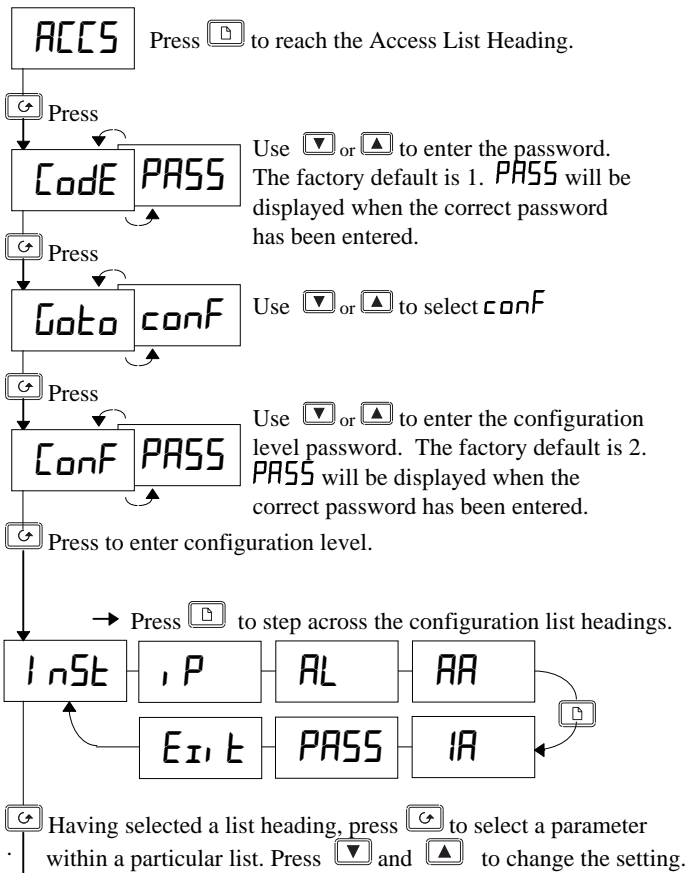

<i>Inst</i>	Instrument list	Options	Meaning
<i>unit</i>	Display units	<i>C</i> <i>F</i> <i>K</i> <i>none</i>	Centigrade Fahrenheit Kelvin None (for linear inputs)
<i>decP</i>	Decimal places in display	<i>none</i> <i>one</i> <i>two</i>	None One Two
<i>ctrl</i>	Control type Selecting <i>On.Off</i> or <i>Pid</i> will convert the indicator into a controller which requires separate instructions.	<i>AL</i>	Always set to <i>AL</i>

The parameters that follow, (*Act*, *Pdtr* and *Pwrf*), are not used by the indicator and require separate instructions.

<i>, P</i>	Sensor Input	Options	Meaning
<i>inpT</i>	Input type	<i>Jtc</i> <i>Ktc</i> <i>Ltc</i> <i>Rtc</i> <i>Btc</i> <i>Ntc</i> <i>Ttc</i> <i>Stc</i> <i>PL 2</i> <i>rEd</i> <i>Ctc</i> <i>mU</i>	J thermocouple K thermocouple L thermocouple R thermocouple B thermocouple N thermocouple T thermocouple S thermocouple Platinell II 100Ω Pt thermometer Custom input- C=st'd Linear mV
<i>CJC</i>	Cold junction compensation	<i>OFF</i> <i>Auto</i> <i>0°C, 45°C or 50°C</i>	OFF - Linear inputs only Automatic external ref.
<i>imp</i>	Sensor break input impedance	<i>Auto</i> = 1.5KΩ, <i>H1</i> = 5KΩ, <i>H1, H1</i> = 15KΩ	

Continued in next column....

Linear input scaling (-12.00 to +80.00mV)		
<i>inpL</i>	mV input low	
<i>inpH</i>	mV input high	
<i>URLL</i>	Displayed value low	
<i>URLH</i>	Displayed value high	

### Alarm Configuration

The *AL* list configures the three internal 'soft' alarms and causes the appropriate alarm message to be flashed in the HOME display.

<i>AL</i>	Alarm list	Options	Meaning
<i>AL 1</i>	Alarm 1	<i>OFF</i> <i>FSL</i> <i>F5H</i>	The alarm is disabled Low alarm High alarm
	<i>Not used in the indicator</i>	<i>dEu</i> <i>dHi</i> <i>dLo</i>	Deviation band alarm Deviation high alarm Deviation low alarm
<i>lTch</i>	Alarm latching	<i>no</i> <b><i>YES</i></b> <i>mAn</i>	Non-latching Special - Not used Latched (manual reset)
<i>bLoc</i>	Alarm blocking	<i>no</i> <b><i>YES</i></b>	No blocking Blocked until first good

The above sequence is repeated for *AL 2* & *AL 3* (Alarms 2 & 3)

<i>SPLi</i>	Alarm setpoint limits	<i>d1</i> <i>5</i> <i>Con</i>	Limited by display range Limited by setpoint limits
-------------	-----------------------	----------------------------------	--

### Relay and Logic input/output Configuration

The *RA* and *IA* lists attach the three internal alarms to the relay and logic outputs. The logic can be configured as an alarm output or as an alarm acknowledge input.

<i>RA</i>	Relay output	Options	Meaning
<i>IA</i>	Logic output		
<i>id</i>	Identity of output	<i>rELY</i> <i>LoG</i>	Relay Logic
<i>Func</i>	Function <i>Logic only</i>	<i>d1G</i> <i>AcAL</i>	Digital output Alarm Ack input
	Functions: <i>HEAT</i> , <i>COOL</i> , <i>SSr.1</i> and <i>rrES</i> are not used by the indicator and require separate instructions		
<i>d1G.F</i>	Digital output functions Any combination of alarms can be attached to the logic or relay output. Press  and  to select a desired alarms After a two second pause the display blinks and returns to <i>d1G.F</i> . Pressing  and  again will show two decimal points in those alarms that have been added to the output	<i>noch</i> <i>CLr</i> <i>1FSL</i> <i>2F5H</i> <i>3F5L</i> <i>5.br</i> ⋮ <i>nw</i>	No change Clear all alarms Alarm 1* Alarm 2* Alarm 3* Sensor break New alarm
	Functions: <i>Lbr</i> , <i>LdF</i> , <i>mAn</i> , <i>End</i> , & <i>EmG 1</i> , to <i>EmG 4</i> are not used by the indicator and need separate instructions		
<i>SEN5</i>	Sense of the output. <i>inu</i> = output de-energised in alarm.	<i>nor</i> <i>inu</i>	Normal Inverted

\*The last three letters will correspond to the alarm type set in the *AL* list. If the alarm is disabled, *AL 1* or *AL 2* or *AL 3* will be shown.

### Passwords

<i>PASS</i>	Passwords	Range	Default
<i>ACCP</i>	Full and Edit level password	0-9999	1
<i>CnFP</i>	Configuration level password	0-9999	2
<i>CALP</i>	User calibration password	0-9999	3

### To leave Configuration level

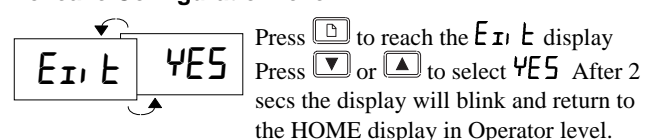

## ORDERING CODE

The indicator is supplied configured according to the ordering code shown below.

Model number	Function	Supply voltage	Manual	Logic I/O	Alarm Relay Output	Sensor input	Setpoint min	Setpoint max	Units	External relay module	Input adaptor
2132i 2116i											

Function	
ND	Indicator only*
AL	Indicating alarm unit

Supply voltage	
VH	85-264Vac
VL	20 -29V dc or ac

Manual	
XXX	None
ENG	English
FRA	French
GER	German
NED	Dutch
SPA	Spanish
SWE	Swedish
ITA	Italian

Logic I/O	
XX	Disabled*
Logic input	
AC	Alarm ack/reset
KL	Keylock
Non-latched alarms	
FH	High alarm 1
FL	Low alarm 1
Latched alarms	
HA	High alarm 1
LA	Low alarm 1
NW	New alarm

Alarm Relay Output	
XX	Disabled*
Non-latched alarms	
FH	High alarm 2
FL	Low alarm 2
AL	High alarm 2 & low alarm 3
Latched alarms	
HA	High alarm 2
LA	Low alarm 2
AA	High alarm 2 & low alarm 3
NW	New alarm

Sensor input		Display range and Setpoint min & max limits	
<b>Thermocouples</b>			
J	Type J	-210 to 1200	-340 to 2192
K	Type K	-200 to 1372	-325 to 2500
T	Type T	-200 to 400	-325 to 750
L	Type L	-200 to 900	-325 to 1650
N	Type N	-200 to 1300	-325 to 2370
R	Type R	-50 to 1768	-58 to 3200
S	Type S	-50 to 1768	-58 to 3200
B	Type B	0 to 1820	32 to 3308
P	Platinell II	0 to 1369	32 to 2496
<b>Resistance thermometer</b>			
Z	Pt100	-200 to 850	-325 to 1562
<b>Custom downloaded inputs</b>			
C	Type C -W5%Re/W26%Re (default custom sensor)	0 to 2319	32 to 4200
D	Type D - W3%Re/W25%Re	0 to 2399	32 to 4350
E	E thermocouple	-200 to 999	-325 to 1830
1	Ni/Ni18%Mo	0 to 1399	32 to 2550
2	Pt20%Rh/Pt40%Rh	0 to 1870	32 to 3398
3	W/W26%Re (Engelhard)	0 to 2000	32 to 3632
4	W/W26%Re (Hoskins)	0 to 2010	32 to 3650
5	W5%Re/W26%Re (Engelhard)	10 to 2300	50 to 4172
6	W5%Re/W26%Re(Bucose)	0 to 2000	32 to 3632
7	Pt10%Rh/Pt40%Rh	200 to 1800	392 to 3272
8	Exergen K80 I.R. Pyrometer	-45 to 650	-49 to 1202
<b>Process inputs (linear)</b>			
M	-9.99 to +80mV	Scalable	-999 to 9999
Y	0 to 20mA	Scalable	-999 to 9999
A	4 to 20mA	Scalable	-999 to 9999
V	0 to 10Vdc (input adaptor required)	Scalable	-999 to 9999

Input Adaptor	
XX	None
V1	0-10Vdc
A1	0-20mA sense resistor (2.49Ω, 0.1%)

External relay module	
XX	Not fitted
R7	Fitted (Operated by the logic output)

Units	
C	°C
F	°F
K	Kelvin
X	Linear input

\*If 'ND' (Indicator only) is specified in the function field, then XX must be entered in the Logic I/O and alarm 2 relay fields.

## TECHNICAL SPECIFICATION

Display	4 digit, green. 10mm high characters
Supply voltage	High voltage unit: 100Vac -15% to 240Vac +10%, 48-62Hz. Power consumption: 5Watts maximum Low voltage unit: 24Vdc or ac -15%, +20% DC to 62Hz, Power consumption: 5Watts maximum
Operating ambients	0 to 55°C. 5 to 95%RH, non condensing
Storage temperature	-30°C to +75°C.
Output ratings	Relay(isolated): Maximum: 264Vac, 2A resistive. Minimum: 12Vdc, 100mA Logic I/O: 9Vdc at 18mA (non-isolated from sensor input). Can be used as alarm output or alarm acknowledge input
Calibration accuracy	± 1°C or ±0.25% of reading whichever is greater
Cold junction compensation	>30 to 1 rejection of ambient temperature change. Uses INSTANT ACCURACY™ cold junction sensing technology to eliminate warm-up drift and respond rapidly to ambient temperature changes.
Input filtering	Off to 999.9 seconds
EMC standards	Generic emissions standard EN50081-2 and immunity standard EN50082-2 for industrial environments
Safety standard	EN 61010. Installation category II. (Voltage transients on the power supply must not exceed 2.5kV). Pollution degree 2. All isolated inputs and outputs have reinforced insulation to protect against electric shock.
Atmosphere	Not suitable for use above 2000m or in explosive or corrosive atmospheres
Panel sealing	IP65 (EN 60529), or NEMA 4X

## SAFETY AND EMC INFORMATION

### Safety

This indicator complies with the European Low Voltage Directive 73/23/EEC, amended by 93/68/EEC, by the application of the safety standard EN 61010.

### Electromagnetic compatibility

This indicator conforms with the essential protection requirements of the EMC Directive 89/336/EEC, amended by 93/68/EEC, by the application of a Technical Construction File. This indicator satisfies the general requirements of the industrial environment defined in EN 50081-2 and EN 50082-2.

### GENERAL

The information contained in these instructions is subject to change without notice. While every effort has been made to ensure the accuracy of the information, Eurotherm Controls shall not be held liable for errors contained herein.

### Unpacking and storage

The packaging should contain the indicator, two panel retaining clips, a 2.49Ω current sense resistor and this instruction leaflet. If the packaging or the indicator are damaged, do not install the product but contact your nearest Eurotherm Controls agent.

Continued on the next page

## SERVICE AND REPAIR

This indicator has no user serviceable parts. Contact your nearest Eurotherm Controls agent for repair.

### Caution: Charged capacitors

Before removing the indicator from its sleeve, switch off the supply and wait two minutes to allow capacitors to discharge. Failure to observe this precaution may damage the indicator or cause some discomfort to the user.

### Electrostatic discharge precautions

When the indicator is removed from its sleeve, it is vulnerable to damage by electrostatic discharge from someone handling the indicator. To avoid this, before handling the unplugged indicator discharge yourself to ground.

### Cleaning

Do not use water or water based products to clean labels or they will become illegible. Isopropyl alcohol may be used to clean labels. A mild soap solution may be used to clean other exterior surfaces of the product.

### Safety Symbols

The following safety symbols are used on the controller:



Caution. Refer to the accompanying documents

### Personnel

Installation must be carried out by qualified personnel.

### Enclosure of live parts

The indicator must be installed in an enclosure to prevent hands or metal tools touching parts that may be electrically live.

### Caution: Live sensors

The logic input/output is electrically connected to the sensor input (e.g. thermocouple). In some installations the temperature sensor may become live. The indicator is designed to operate under these conditions, but you must ensure that this will not damage other equipment connected to the logic input/output and that service personnel do not touch this connection while it is live. With a live sensor, all cables, connectors and switches for connecting the sensor and non-isolated inputs and outputs must be mains rated.

## INTERNATIONAL SALES AND SERVICE

### EUROTHERM CONTROLS LTD

Faraday Close, Durrington, Worthing,  
West Sussex BN13 3PL  
Telephone Sales: (01903) 695888  
Technical: (01903) 695777  
Service: (01903) 695444  
Fax (01903) 695666

For countries not listed enquiries/orders to:  
Eurotherm Controls Limited,  
Export Dept., Faraday Close, Durrington,  
Worthing, West Sussex, BN13 3PL  
Telephone (01903) 268500  
Fax (01903) 265982

### AUSTRALIA

Eurotherm Pty. Ltd.  
Telephone Sydney (+61 2) 9477 7022  
Fax (+61 2) 9477 7756

### AUSTRIA

Eurotherm GmbH  
Telephone Vienna (+43 1) 798 7601  
Fax (+43 1) 798 7605  
Telex 047 1132000 EIAUT A

### BELGIUM

Eurotherm B.V.  
Telephone Antwerp (+32 3) 322 3870  
Fax (+32 3) 321 7363

### DENMARK

Eurotherm A/S  
Telephone Copenhagen (+45 31) 871622  
Fax (+45 31) 872124

### FRANCE

Eurotherm Automation SA  
Telephone Lyon (+33 478) 664500  
Fax (+33 478) 352490

### GERMANY

Eurotherm Regler GmbH  
Telephone Limburg (+49 6431) 2980  
Fax (+49 6431) 298119  
Also regional offices

### HONG KONG

Eurotherm Limited  
Telephone Hong Kong (+852) 2873 3826  
Fax (+852) 2870 0148  
Telex 0802 69257 EIFEL HX

### INDIA

Eurotherm India Limited  
Telephone Chennai (+9144) 4961 129  
Fax (+9144) 4961 831

## Wiring

Wire the indicator in accordance with the wiring data given in these instructions. Take particular care not to connect AC supplies to the low voltage sensor input or logic outputs. Only use copper conductors for connections, (except thermocouple). Use a minimum of 0.5mm<sup>2</sup> or 16swg wire for plant connections. Ensure that the installation complies with local wiring regulations.

### Power Isolation

The installation must include a power isolating switch or circuit breaker that disconnects all current carrying conductors. The device should be mounted in close proximity to the indicator, within easy reach of the operator and marked as the disconnecting device for the indicator.

### Voltage rating

The maximum continuous voltage applied between any connection and ground must not exceed 264Vac.

For the above reason the indicator should not be wired to a three phase supply with an unearthed star connection. Under fault conditions such a supply could rise above 264Vac with respect to ground and the product would not be safe.

### Conductive pollution

Electrically conductive pollution (for example carbon dust) must be excluded from the cabinet in which the indicator is mounted. Where condensation is likely, for example at low temperatures, include a thermostatically controlled heater in the cabinet.

### Installation requirements for EMC

- For general guidance refer to Eurotherm Controls EMC Installation Guide, HA025464.
- It may be necessary to fit a filter across the relay output to suppress conducted emissions. The filter requirements will depend on the type of load. For typical applications we recommend Schaffner FN321 or FN612.

### Routing of wires

To minimise the pick-up of electrical noise, the sensor input wiring should be routed away from high-current power cables. Where it is impractical to do this, use shielded cables with the shield grounded at both ends.

### IRELAND

Eurotherm Ireland Limited  
Telephone Naas (+353 45) 879937  
Fax (+353 45) 875123

### ITALY

Eurotherm SpA  
Telephone Como (+39 31) 975111  
Fax (+39 31) 977512  
Telex 380893 EUROTH I

### JAPAN

Eurotherm Japan Limited  
Telephone Tokyo (+81 3) 33702951  
Fax (+81 3) 33702960

### KOREA

Eurotherm Korea Limited  
Telephone Seoul (+82 2) 5438507  
Fax (+82 2) 545 9758  
Telex EIKOR K23105

### NETHERLANDS

Eurotherm B.V.  
Telephone Alphen a/d Ryn (+31 172) 411752  
Fax (+31 172) 417260

### NEW ZEALAND

Eurotherm Limited  
Telephone Auckland (+64 9) 2635900  
Fax: (+64 9) 2635901

### NORWAY

Eurotherm A/S  
Telephone Oslo (+47 66) 803330  
Fax (+47 66) 803331

### SPAIN

Eurotherm España SA  
Telephone (+34 91) 6616001  
Fax (+34 91) 6619093

### SWEDEN

Eurotherm AB  
Telephone Malmo (+46 40) 384500  
Fax (+46 40) 384545

### SWITZERLAND

Eurotherm Produkte (Schweiz) AG  
Telephone Zurich (+41 55) 4154400  
Fax (+41 55) 4154415

### UNITED KINGDOM

Eurotherm Controls Limited  
Telephone Worthing (+44 1903) 269888  
Fax (+44 1903) 269666  
<http://www.eurotherm.co.uk>

### U.S.A

Eurotherm Controls Inc.  
Telephone Reston (+1 703) 787 3405  
Fax (+1 703) 787 3436

**ENG**